

**Wattages: 20W,25W,30W,34W,38W,45W**



The Sensor Based LED Troffer Lighting Series can be widely used for Indoor Excellent for Offices, Hallways, Multipurpose Rooms , Office Buildings, Conference Rooms,super market, store and many other applications.

Lighting controls meet design lights consortium (DLC) networked lighting control system technical requirements, LLLC, Energy Monitoring and High End Trim function.



### Features:

- Energy efficient: save up to 80% in energy costs
- High lumen output
- Mercury-free
- Instant-on light
- 50,000 hours at 70% lumen maintenance rated life
- 5 years manufacturer warranty
- Compatible with most Lutron and Leviton dimmers
- 12Vdc auxiliary dimming
- The 0-10V Dimming type is continuous

### Packaging information:

❖ **14TRF202530W27-3545K-G2:**  
1230MMX307MMX113MM(2Pcs/CTN)  
(48.4" X12.1" X4.4" )

❖ **22TRF202530W27-3545K-G2:**  
617MMX610MMX123MM(2Pcs/CTN)  
(24.3" X24.0" X4.8" )

❖ **24TRF343845W27-3545K-G2:**  
1227MMX610MMX123MM(2Pcs/CTN)  
(48.3" X24.0" X4.8" )

SPECIFICATION			
TYPE	14TRF202530W27-3545K-G2	22TRF202530W27-3545K-G2	24TRF343845W27-3545K-G2
WATTAGE	20W/25W/30W	20W/25W/30W	34W/38W/45W
LUMEN	2500 lm/3225 lm/3950lm	2570 lm/3125 lm/3850lm	4250 lm/4758 lm/5715lm
15W EMERGENCY LUMEN	1725lm (WSD-EMLY15W27-XX)		
EFFICACY	> 125 lm/W		
CCT	3500K,4000K,5000K		
CRI	> 80		
INPUT VOLTAGE	AC120-277V		
FACTORY SETTINGS	30W & 4000K		45W & 4000K
LIGHTING ANGLE	119°		
LED TYPE	SMD2835		
PF	> 0.98		
DRIVER EFFICIENCY	> 90%		
PROTECTION LEVEL	Damp		
LIFE TIME	> 75000 hours		
IC RATING	Type IC		
WARRANTY	5 year limited		

**Wattages: 20W,25W,30W,34W,38W,45W**

### DIMENSION:

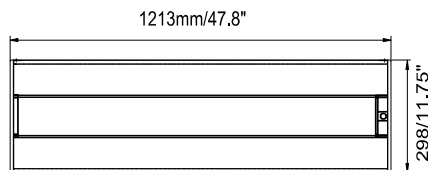

**1X4 feet**

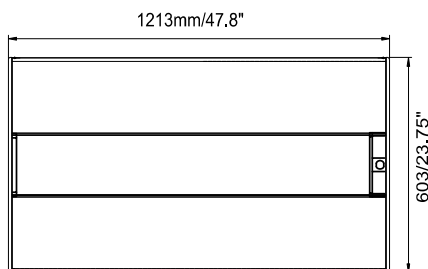

**2X4 feet**

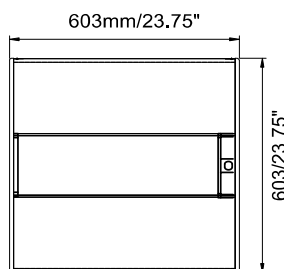

**2X2 feet**

### Specifications:

#### Troffer-14/22/24

**Length:** 1213MM/603MM/1213MM  
(47.8"/23.75"/47.8")

**Width:** 298MM/603MM/603MM  
(11.75"/23.75"/23.75")

**Depth:** 50MM/54MM/54MM(2.0"/2.13"/2.13")

**Weight:** 7.7/6.8/11.4(lbs)

### Mounting:

- ❖ Embedded installation.

### CONTROL MODULE:

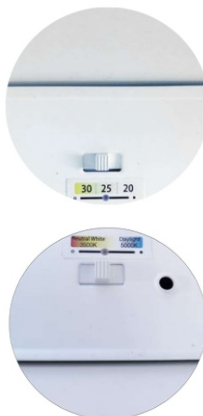

**WATT/CCT**  
**SELECTABLE**



**Selectable CCT**

Three position sliding switch  
3500K / 4000K / 5000K



**Selectable Power**

Three position sliding switch  
20W / 25W / 30W  
34W / 38W / 45W

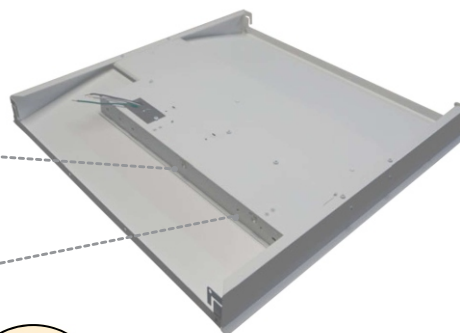

### Multiple sensor solutions ready

- Quick and easy in-field installation of sensors.

- Integrated occupancy and daylight controls.



The sensor receptacle is pre-embedded in the profile frame.

**Wattages: 20W,25W,30W,34W,38W,45W**

**ACCESSORIES: (SOLD SEPARATELY)**



**WSD-EMLY15W27-XX**  
15W Emergency Backup  
Battery LED Driver

**6FTPRWG-3/8-3PIN**  
**6FTPRWG-3/8-5PIN**  
**6FTPRWG-3/8-6PIN**  
6FT 3/8 inch Metal Flexible Conduit

**CONTROL (SOLD SEPARATELY)**



**Bluetooth**  
**ANT-1P-4T-BLE-SR**  
PIR Bluetooth  
Microwave Sensor  
For Silvir Systems



**ANT-1P-4T**  
Bi-Level PIR  
Infrared Sensor



**RC100**(With ANT-1P-4T use)  
Remote Controller

**ACCESSORIES: (ACCESSORIES NEED TO PURCHASED SEPARATELY)**



**WSD-TF14FRAME-W**  
2X2 feet SURFACE MOUNT KIT



**WSD-TF22FRAME-W**  
2X4 feet SURFACE MOUNT KIT



**WSD-TF24FRAME-W**  
1X4 feet SURFACE MOUNT KIT

**WSD-TBAR Mounting Kit( SOLD SEPARATELY)**



Emergency LED Driver

**WSD-TBAR**  
Emergency Backup  
Battery LED Driver Mounting  
Kit

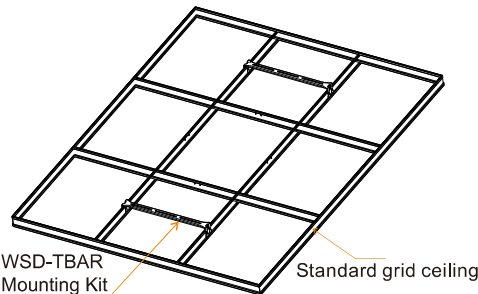

WSD-TBAR  
Mounting Kit

Standard grid ceiling

WSD-TBAR Mounting Kit for Emergency LED Driver When emergency led drivers can not be installed on the LED lights such as LED downlights, LED panel lights&LED troffer. We can install the emergency led drivers on the WSD-TBARs and WSD-TBARs are installed on the grid ceiling.

**Wattages: 20W,25W,30W,34W,38W,45W**



### DIMENSION

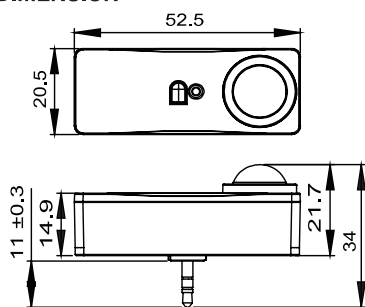

### COVERAGE

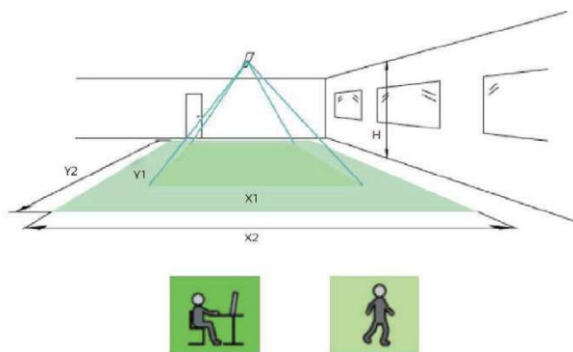

Height	Minor Movement		Major Movement	
	Y1	X1	Y2	X2
8'1/2.4m	10'1/2.9m	9'1/2.7m	15'1/4.5m	9'1/2.9m
10'1/3m	12'1/3.6m	11'1/3.4m	18'1/5.4m	12'1/3.6m

Note: Longer dimension of detection area (Y1, Y2) is parallel to longer dimension.

### ANT-1P-4T-BLE-SR

Plug and Play Network BLE Nodes and Sensor

The ANT-1P-4T-BLE-SR uses PIR motion detector architecture and passive infrared (PIR) technology for improved detection coverage for high bay applications.

### FEATURES

- Bluetooth to 0-10V signal converter, Bluetooth mesh network.
- Built-in 20mA 0-10V signal output.
- Mesh network, which has a much longer control distance, transmits received signals to neighboring devices.
- All devices on 0-10V line are broadcast controlled by mobile application
- In typical outdoor environment, the typical range for wireless communication is 60m.
- Actual range is dependent on field installation.
- Available with Magnetic reset (Touch the top part of sensor for 5 seconds).
- On-board antenna.

### SPECIFICATION

NETWORK BLE MESH	Yes
DAYLIGHT HARVESTING	Yes
MICROWAVE MOTION SENSOR	Yes
MOTION SENSOR	Passive infrared sensor
OPERATING VOLTAGE	10-14V DC
OPERATING CURRENT	>50mA
SINKING CURRENT	max. 25mA
CONTROL OUTPUT	0-10V
RADIO FREQUENCY	2.4GHz ± 75MHz
DETECTION ANGLE	360 °
PROGRAMMING	Silvair iOS App ( IOS )
CYBERSECURITY	UL
MOUNTING HEIGHT	12ft Max.
MAX BLUETOOTH RANGE	200ft
SAFETY	cULus Listed
FCC	FCC
OPERATING TEMP.	-20°C - +60°C
IP RATING	IP20
WARRANTY	5 year limited

### COMMISSIONING

Silvair iOS App makes it easy to pair devices, create groups, set scenes/schedules, customize dimming levels, and adjust high trim based on application needs.

Please scan and download the app:



iOS

Operation Instruction:

[https://youtu.be/8KWPK7z\\_Tng](https://youtu.be/8KWPK7z_Tng)

Wattages: 20W,25W,30W,34W,38W,45W

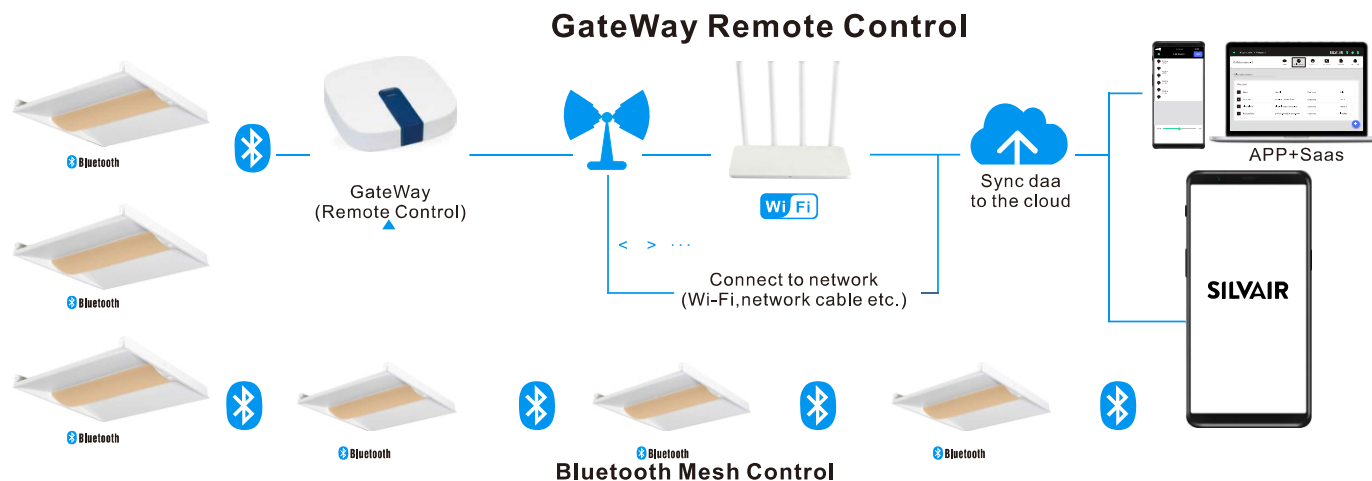

### INDUSTRIAL GATEWAY

#### SGW-101

Smart Engineering Gateway

The Silvair Gateway connects Bluetooth mesh networks that have been commissioned using the Silvair Commissioning tools to the Silvair cloud. This allows the scheduling of events and delivery of services based on the data generated by these networks.

#### SPECIFICATION

<b>POWER SUPPLY</b>	4.5-5.5 V DC, 2 A Power over Ethernet 36-57 V DC (IEEE 802.3af)
<b>OPERATING SYSTEM</b>	Ubuntu Core
<b>PROCESSOR</b>	1.MX6ULL (Y2), 32-bit ARM 800 MHz
<b>MEMORY</b>	512 MB DDR3L SDRAM 8GB eMMC
<b>COMMUNICATION PROTOCOLS</b>	Bluetooth mesh (2.4 GHz Bluetooth Low Energy) Wi-Fi 802.11a/b/g/n/ac (2.4/5 GHz) 4G LTE Cat 1 with 2G/3G (only for Cascade-500-W and Cascade-500-X gateways)
<b>PORTS</b>	1 x RJ45 10/100 Ethernet 1 x USB 2.0 Type-A 2 x external dipole antenna, 5 dBi (only for Cascade-500-W and Cascade-500-X gateways)
<b>REQUIRED AMBIENT TEMPERATURE</b>	0°C to 60°C 32°F to 140°F
<b>ENCLOSURE DIMENSIONS</b>	127 mm x 127 mm x 30 mm (5 inch x 5 inch x 1.2 inch)
<b>MOUNTING POSITION</b>	Wall or surface mounted. As close to the geometrical center of the lighting network as possible, but as far as possible from potential sources of interference.
<b>SECURITY</b>	Secure boot with encrypted operating system Secure communication with the Silvair Cloud over Internet (TLS) Secure communication with devices over qualified Bluetooth mesh

#### Functions:

The Silvair Gateway enables the following functions in the Silvair web app: • Scheduling (available by default)

- Scheduling changes in scenes and lighting control scenarios (for example occupancy sensing, daylight harvesting) for specific times or days.
- Energy and occupancy monitoring (additional paid service)
  - Visualizing energy use and occupancy via the Silvair web app.
  - Downloading energy and occupancy via the Silvair web app and cloud-based API.
- Remote monitoring and control (additional paid service)
  - Low-latency monitoring of the status of devices in the network via API.
  - Low-latency control of devices in the network via API.
- System diagnostics
  - Monitoring of the status of Bluetooth mesh networks.
  - Remote troubleshooting of networking issues.

#### Features:

- Future-proof Linux operating system.
- Simple commissioning using the Silvair Commissioning tools.
- Automatic connection to the Silvair cloud.
- Secure provisioning with secure IDs and encrypted keys.
- High level of hardware and software security (secure boot and encrypted file system can only be accessed with the management platform).
- Automatic security updates.
- Prompt releases of OS updates and fixes to vulnerabilities.
- Low-latency transfer of network, luminaire, and sensor status data to the Silvair cloud.
- Schedule caching.
- Automatic remote firmware updates.
- Display of gateway and network performance metrics (requires the Silvair web app).

**Wattages: 20W,25W,30W,34W,38W,45W**

### ORDERING INFORMATION:

#### EXAMPLE:

**14TRF202530W27-3545K-E[Blank,BLE,EC,M,ECM]-G2**

14	TRF	202530	27	3545K	E	G2
SIZE	PRODUCT	POWER	VOLTAGE	CCT	CONTROL	UPDATE
14 - (1X4feet) 22 - (2X2feet) 24 - (2X4feet)	TRF Led Troffer Light	202530/343845 20W/25W/30W 34W/38W/45W	27 AC120-277V	3545 3500K/4000K/5000K	BLE(Bluetooth) EC(Emergency) M(Motion Sensor) ECM(Emergency+ Motion Sensor)	Second generation product

### PHOTOMETRICS:

*For complete IES files, please visit our website.*

#### 14TRF202530W27-3545K-G2 (30W&3500K)

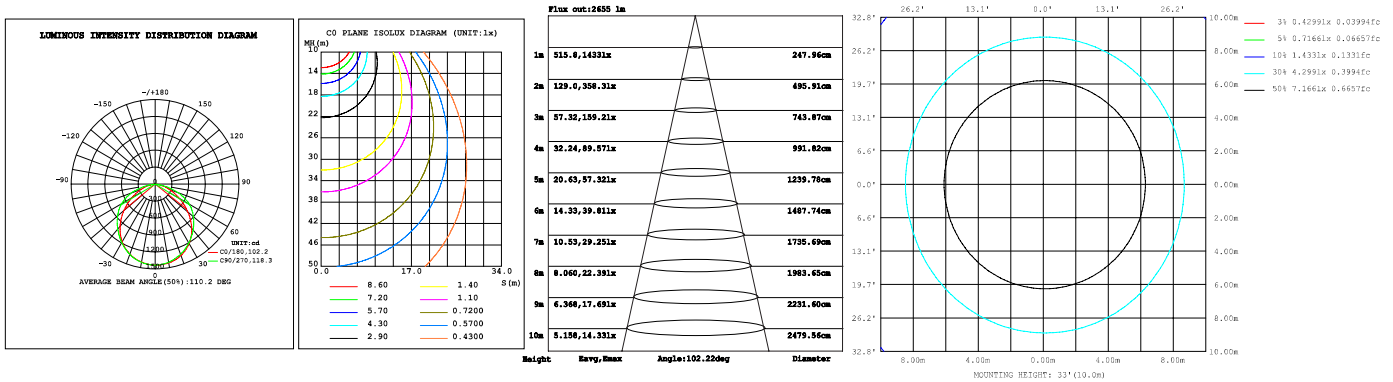

#### 22TRF202530W27-3545K-G2 (30W&3500K)

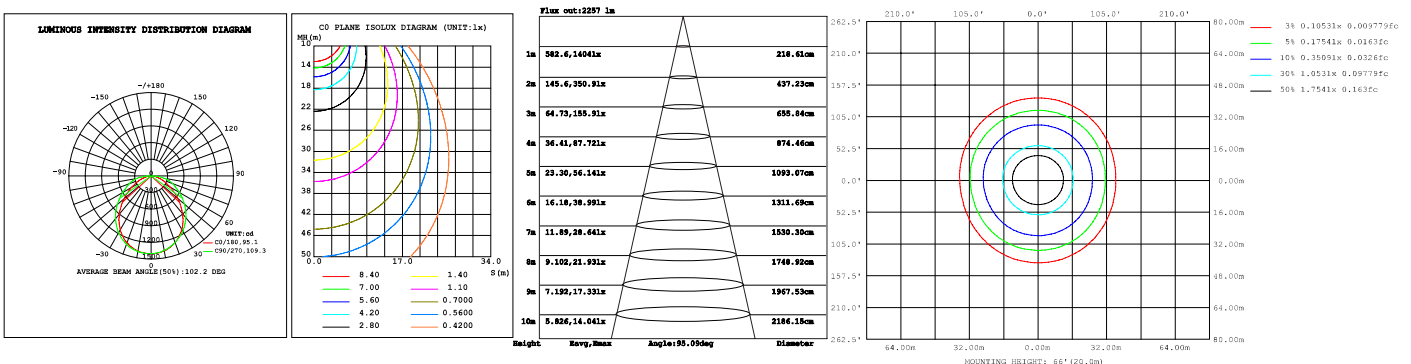

**Wattages: 20W,25W,30W,34W,38W,45W**

**PHOTOMETRICS:**

*For complete IES files, please visit our website.*

**24TRF343845W27-3545K-G2 (45W&3500K)**

