

## LED SOLAR STREET LIGHT – RB Series SLD (BAA / BABA)



### PRODUCT OVERVIEW

Solar energy is a green renewable and clean energy that is pollution-free, noise-free and inexhaustible. When solar panels receive sunlight, they generate photovoltaic effect to generate electrical energy that uses a controller to store in a battery. After the sun sets, the batteries discharge stored electricity to power LED lights.

### FEATURES

- The patented design integrates an A-type Lithium battery pack and lamp body controller.
- Fully automatic intelligent light control, time control and remote-control function. Charges during the day and automatically generates light at night.
- One-piece aluminum housing, high efficiency light source, full power solar panel.
- Anti-corrosion coating.
- IP65 waterproof.
- Lightning/surge protection.
- Easy to install – no wiring required.
- Mounts to poles, walls, roof, columns or anywhere exposed to sunlight.
- Solar panel efficiency conversion rate of 18% or more.
- Normal sunshine charging more than 8 hours can supply 3-4 rainy days and evening (12 hours per night).

### APPLICATIONS

- Highways
- City streets
- Rural roads
- Parking lots
- Courtyard lighting
- Driveways



Buy America Act and Build America Buy America certified.

### Product Description

PART#	DESCRIPTION	MAX POWER	RANGE	LED QTY	BATTERY
BB-SLD-50W-A2	50W LED Solar Powered Area Light	18V/40W	40m <sup>2</sup>	96	12.6V/18AH
BB-SLD-80W-A2	80W LED Solar Powered Area Light	18V/50W	60m <sup>2</sup>	144	12.6V/22AH
BB-SLD-100W-A2	100W LED Solar Powered Area Light	18V/70W	80m <sup>2</sup>	192	12.6V/30AH
BB-SLD-200W-A3	200W LED Solar Powered Area Light	18V/100W	80m <sup>2</sup>	192	12.6V/36AH

## LED SOLAR STREET LIGHT – RB Series SLD (BAA / BABA)

### Specifications

MODEL#	BB-SLD-50W-A2	BB-SLD-80W-A2	BB-SLD-100W-A2	BB-SLD-200W-A3
Power	50W	80W	100W	200W
Solar Panel Max Power	18V/40W	18V/50W	18V/70W	18V/100W
Lamp Size	615*365*160mm	720*365*160mm	930*365*160mm	1435*400*280mm
Range	40m <sup>2</sup>	60m <sup>2</sup>	80m <sup>2</sup>	80m <sup>2</sup>
Mounting Height	3-4m	5-6m	6-7m	7-8m
LED Quantity	96	144	192	300
Battery (Lithium Iron)	12.8V/12AH	12.8V/18AH	12.8V/24AH	12.8V/36AH
Sensor	Motion sensor, photocell			
Controller	PWM controller, MPPT controller optional			
Material	High quality aluminum alloy housing			
Discharge Time	More than 12 hours			
Charge Time	6-8 hours (with adequate sunlight)			
Solar Cell	High efficiency single silicon solar panel			
Light Source	SMD LED			
Operating Temperature	-40 to +55°C			
CCT	2700K SW / 3000K WW / 4100K NW / 5000K DW / 5700K CW			
CRI	70+			
Material	Metal alloy + PC lens			
Color	Silver/bronze (customized)			
Lifespan	50,000 hours			
Ingress Protection	IP65			
Beam Angle	120°			
Warranty	3 years			

### Ordering Information

SERIES	WATTS	VERSION	CONTROL	CCT	INSTALLATION	COLOR
BB-SLD	50W 80W 100W 200W	A2   A3	Blank - Photocell Sensor Motion Sensor	SW-2700K WW-3000K NW-4100K DW-5000K CW-5700K SCW-6500K	A – Round pole mounting B- Bracket Mounting C – Aluminum sleeve mounting	Silver Bronze (Customized)

**LED SOLAR STREET LIGHT – RB Series SLD (BAA / BABA)**

**Dimensions**

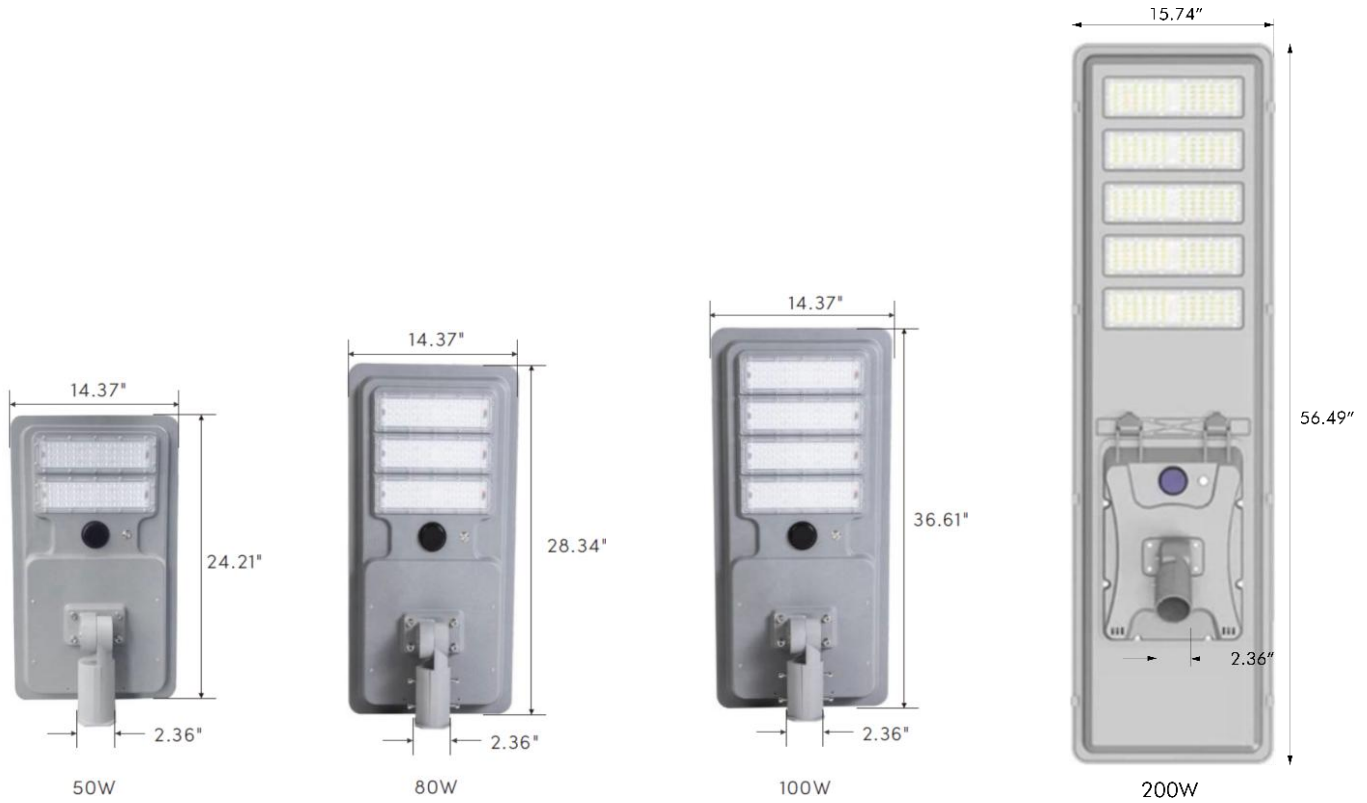

**Feature Detail**



**Installation**

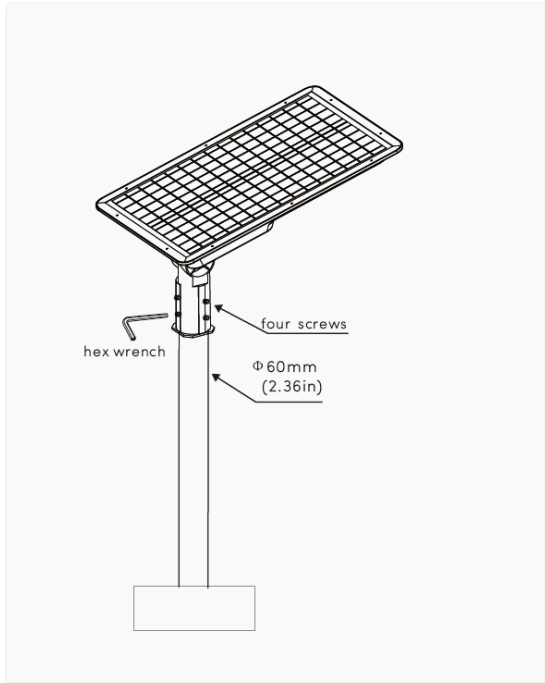

1.Round pole Mounting

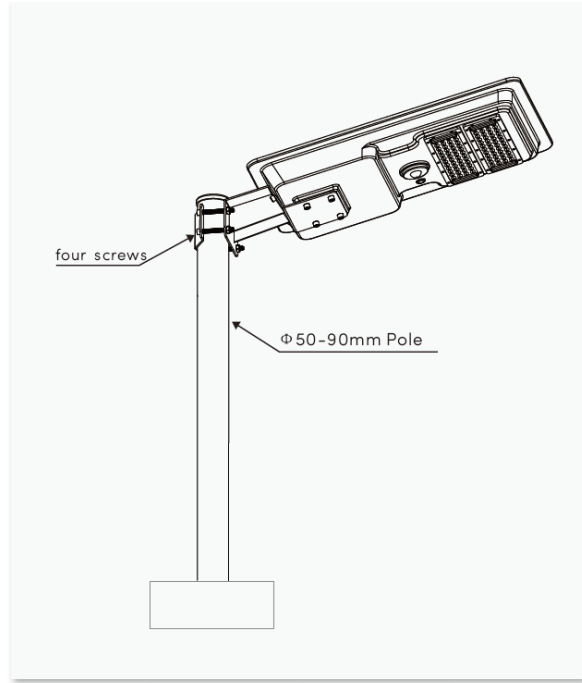

2.Bracket Mounting

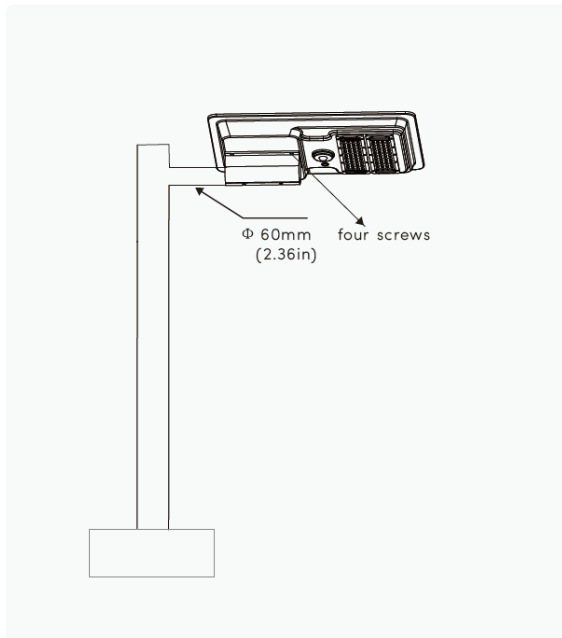

3.Aluminum sleeve mounting

Mounting Bracket:

